

STRAIGHT PLUG CRIMP TYPE

R143.092.700

CABLE 8.07/50 D

Series : TNC-P

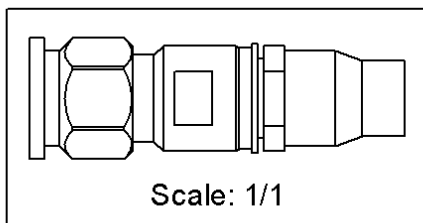
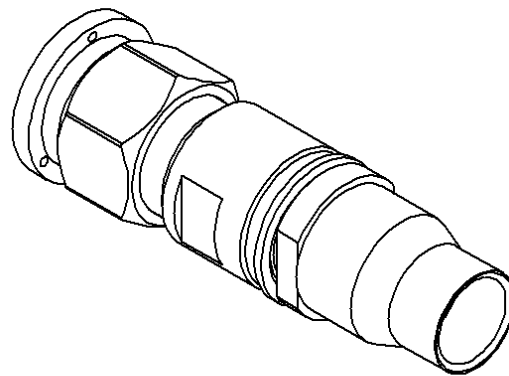
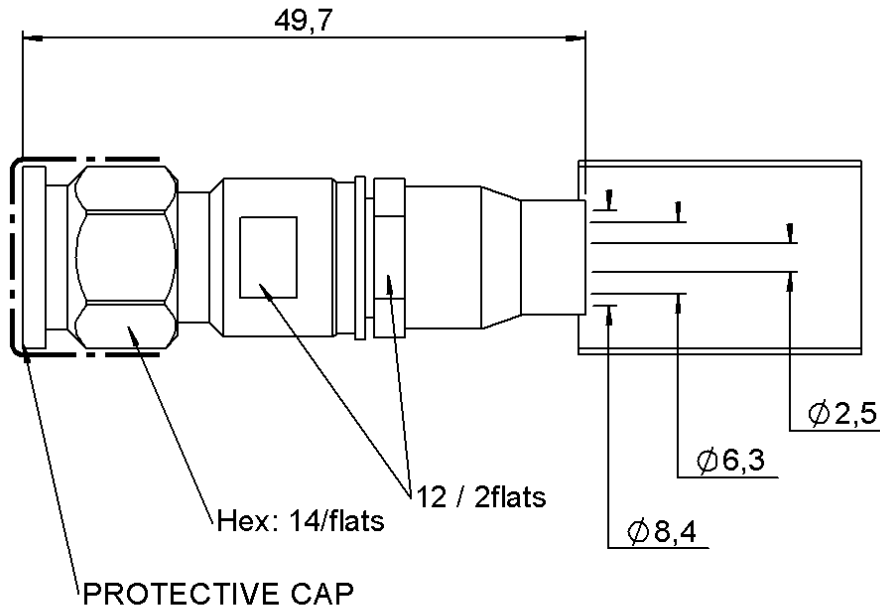

All dimensions are in mm.



COMPONENTS	MATERIALS	PLATINGS (μm)
BODY	STAINLESS STEEL	PASSIVATED
CENTER CONTACT	BRASS	GOLD 0.5 OVER NICKEL 2
OUTER CONTACT	STAINLESS STEEL	PASSIVATED
INSULATOR	PTFE	
GASKET	SILICONE RUBBER	
OTHERS PARTS	BRASS	NICKEL 2
-	-	-
-	-	-

Issue : 0808



In the effort to improve our products, we reserve the right to make changes judged to be necessary.

STRAIGHT PLUG CRIMP TYPE

R143.092.700

CABLE 8.07/50 D

Series : **TNC-P**

PACKAGING

Standard	Unit	Other
1	'W' option	Contact us

SPECIFICATION

- - QAE 06-02A ASN-E 0461F02

ELECTRICAL CHARACTERISTICS

Impedance		50 Ω
Frequency		0-5 6 GHz
VSWR	1.15 +	0,0000 x F(GHz) Maxi
Insertion loss		0.15 √F(GHz) dB Maxi
RF leakage	- (- F(GHz)) dB Maxi
Voltage rating		500 Veff Maxi
Dielectric withstanding voltage		1000 Veff mini
Insulation resistance		5000 MΩ mini

CABLE ASSEMBLY

Stripping	a	b	c	d	e	f
mm	9,00	9,00	27,0	0,00	0,00	0,00

Assembly instruction :

Recommended cable(s)
50 MFCFB FTX

Characteristics indicated on this data sheet are those that can be achieved with the highest performance cable. Intrinsic limitations of the cable may diminish the performance of the assembly

Cable retention

- pull off	180 N mini
- torque	NA N.cm

MECHANICAL CHARACTERISTICS

Center contact retention		
Axial force – Mating end	27	N mini
Axial force – Opposite end	27	N mini
Torque	NA	N.cm mini

TOOLING

Part Number	Description	Hexagon
.	.	.
282.247	CRIMPING DIE M 22520/5-61	10.90
282.291	CRIMPING TOOL M22520/1-01	2x4 (pos 7)
R282.293.000	CRIMPING TOOL M22520/5-01	-
282.997	POSITIONER FOR TOOL 282.291	rouge

Recommended torque		
Mating	265	N.cm
Panel nut	NA	N.cm
Clamp nut	370	N.cm
A/F clamp nut	12,0000	mm

Mating life	500	Cycles mini
Weight	32,5780	g

ENVIRONMENTAL

Operating temperature	-65/+165	° C
Hermetic seal	NA	Atm.cm3/s
Panel leakage	-	

OTHERS CHARACTERISTICS

Issue : 0808



In the effort to improve our products, we reserve the right to make changes judged to be necessary.